

New Product Bulletin

S-band 750kW Magnetron

M1901S

M1901S is a mechanically tunable frequency pulsed type S-band magnetron; designed to operate in the frequency range of 2.7 GHz to 2.9 GHz with a peak output power of 750kW.

It is a coaxial line output type and is forced air cooled. A permanent magnet is separated.



GENERAL CHARACTERISTICS

----ELECTRICAL----

Heater voltage	(note 2).	16 V
Heater current		3.1 A
Minimum preheat time	(note 3)	120 sec

----MECHANICAL----

Dimensions	See outline drawing
Net weight	2.5 kg approximately
Mounting position	Any
Cooling (note 5).	Forced air.
Output coupling	Coaxial line See page 8

All specifications are subject to change without notice.

New Japan Radio Co., Ltd.

ABSOLUTE MAXIMUM RATINGS

These ratings cannot necessarily be used simultaneously, and no individual ratings should be exceeded.

	Min	Max	Units
Heater voltage (note 2)	14.4	17.6	V
Cathode preheating time (note 3)	120	-	sec
Peak anode voltage	-	32	kV
Peak anode current	-	45	A
Input power (peak)	-	2200	kW
Input power (average) (note 6)	-	1200	W
Rate of rise of voltage pulse (note 7)	-	200	kV/ μ s
Duty cycle	-	0.001	—
Pulse duration	-	2.5	μ s
Anode temperature (note 5)	-	100	$^{\circ}$ C
Altitude	-	3000	m
V.S.W.R at load	-	1.5:1	—
Pressurizing of output circuit (note 8)	-	45	lb/in ²

TEST CONDITIONS AND LIMITS

The tube is tested to comply with the following electrical specification:

Test conditions

Magnetic field (note 1)	270 \pm 5	mT
	2700 \pm 50	gauss
Heater voltage (for test)	10	V
Anode current (peak)	40	A
Duty cycle	0.001	
Pulse duration (note 9)	1.0	μ s
V.S.W.R. at the output coupler	1.15:1	
Rate of rise of voltage pulse (note 7)	200	kV/ μ s
Pressurizing of output circuit	40~45	lb/in ²
	2.8~3.2	kg/cm ²

Limits

	Min	Max	
Anode voltage (peak) (note 10)	27	32	kV
Output power (mean) (note 10)	500	-	W
Frequency (note 11)	2700	2900	MHz
R.F. bandwidth at 1/4 power (note 12)	-	2.5	MHz
Stability (notes 10 and 13)	-	1	%
Heater current	(note 14)		

All specifications are subject to change without notice.

New Japan Radio Co., Ltd.

LIFE TESTLife Test conditions

Magnetic field	(note 1)	—————	270±5	mT
			2700±50	gauss
Heater voltage (for test)		—————	10	V
Anode current (peak)		—————	40	A
Duty cycle		—————	0.001	
Pulse duration	(note 9)	—————	1.0	μ s
V.S.W.R. at the output coupler		—————	1.15:1	
Rate of rise of voltage pulse	(note 7)	———	200	kV/μ s
Pressurizing of output circuit		—————	40~45	lb/in ²
			2.8~3.2	kg/cm ²

End of Life Criteria

			Min	Max	
Output power (mean)		—————	400	-	W
R.F. bandwidth at 1/4 power		—————	-	2.5	MHz
Stability	(notes 13)	—————	-	1	%

NOTE:

1. The magnetron is designed for use with a separate magnet which must conform with the specification given on page 6. The axis of the magnetic field must be coincident with the axis of the anode, and the north pole of the magnet must be adjacent to the cathode terminal.

2. With no anode input power.

During high voltage operation it is essential to operate the heater according to the following schedule:

Mean Input Power (W)	Heater Voltage (V)
1000-1200	8.0
800-1000	10.5
600-800	13.0
400-600	15.0
less than 400	16.0

The above schedule is valid only for pulse repetition rates of 300p.p.s. or greater. The magnetron heater shall be protected against arcing by use of a minimum capacitance of 4000pF shunted across the heater directly at the terminals; in some cases a capacitance as high as 2 μ F may be necessary depending on the equipment design.

3. It has been verified that the magnetron will operate at ambient temperatures as low as -55°C. At this temperature the minimum cathode heating time is 3 minutes.

All specifications are subject to change without notice.

New Japan Radio Co., Ltd.

4. Tuning is achieved by rotating a splined shaft which can be fitted to the magnetron in two positions as shown on the outline drawing.
5. The anode temperature must be kept below the limit specified by means of a suitable flow of air over the cooling fins.
6. The various parameters are related by the following formula:

$$P_i = i_{apk} \times V_{apk} \times D_u$$

Where P_i =mean input power in watts
 i_{apk} =peak anode current in amperes
 V_{apk} =peak anode voltage in volts
and D_u =duty cycle
7. The rate of rise of voltage is the slope of the steepest tangent to the leading edge of the voltage pulse above 80% amplitude. Any capacitance used in the viewing system must not exceed 6.0 pF.
8. The mounting plate and the guard pipe are fitted to the magnetron in a manner to permit pressurizing of the input and the output circuit of the magnetron. At the maximum pressure of 45 lb/in²(3.2kg/cm²) absolute, the leakage will not exceed 0.5 liter (N.T.P.) per minute.
9. Tolerance $\pm 10\%$
10. These tests are carried out at 2700, 2800 and 2900MHz.
11. The magnetron will tune over the indicated frequency range.
12. The specification limit for bandwidth applies over the whole tuning range.
13. Pulses are defined as missing when the r.f. energy level is less than 70% of the normal energy level in the rated frequency range of the magnetron. Missing pulses are expressed as a percentage of the number of input pulses applied during the last 3 minutes of a test interval not to exceed 6 minutes.
14. Measured with heater voltage of 16V and no anode input power, the heater current limits are 2.8A minimum, 3.4A maximum.

X-RAY WARNING

High voltage magnetrons emit a significant intensity of X-rays not only from the cathode sidearm but also from the output waveguide. These rays can constitute a health hazard unless adequate shielding for X-ray radiation is provided. This is a characteristic of all magnetrons and the X-rays emitted correspond to a voltage much higher than of the anode.

All specifications are subject to change without notice.

New Japan Radio Co., Ltd.

OUTLINE

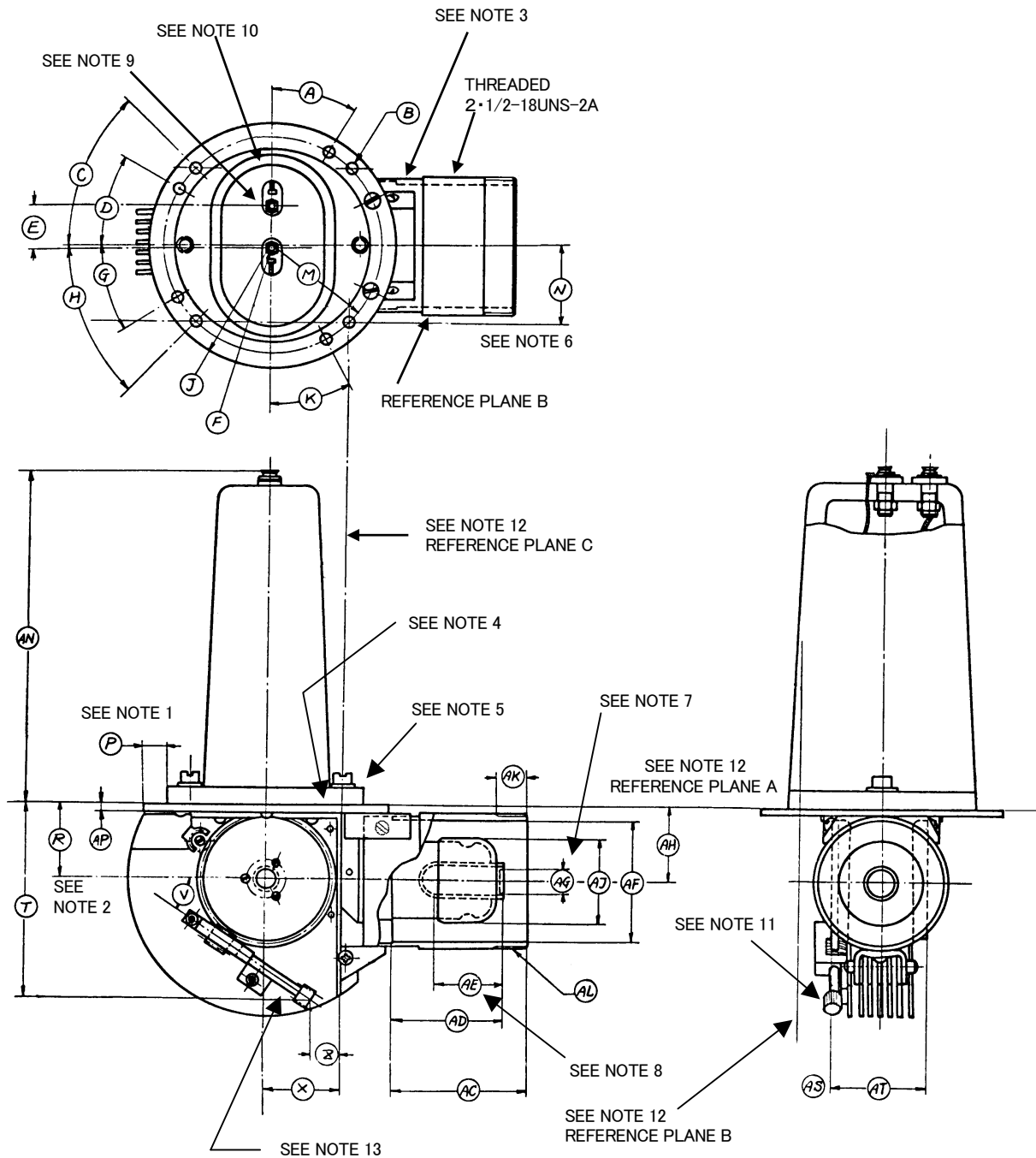

All specifications are subject to change without notice.

New Japan Radio Co., Ltd.

Outline Dimensions (All dimensions without limits are nominal)

Ref	Inches	Millimeters	Ref	Inches	Millimeters
A	30° ±12'	30° ±12'	AC	2.297±0.010	58.34±0.25
B	0.210±0.005	5.33±0.13	AD	2.085±0.025	52.96±0.64
C	45° ±12'	45° ±12'	AE	1.125min	28.58min
D	30° ±12'	30° ±12'	AF	2.321±0.007	58.95±0.18
E	0.796±0.015	20.24±0.38	AG	0.555±0.005	14.10±0.13
F	DIA0.169±0.005	DIA4.29±0.13	AH	1.440±0.020	36.58±0.51
G	30° ±12'	30° ±12'	AJ	1.620max	41.15max
H	45° ±12'	45° ±12'	AK	0.593min	15.06min
J	RAD2.281±0.015	RAD57.94±0.38	AN	6.313±0.094	160.4±2.4
K	30° ±12'	30° ±12'	AP	0.187	4.75
M	RAD2.032±0.003	RAD51.61±0.08	AS	0.575±0.050	14.61±1.27
N	1.437±0.020	36.5±0.51	AT	1.740max	44.20max
P	0.500min	12.70min			
R	1.440	36.58			
T	3.500	88.90			
V	32.5° ±2.5°	32.5° ±2.5°			
X	1.437	36.50			
Z	0.756	19.20			

Millimeter dimensions have been derived from inches.

ELECTRO-MAGNET POLEPIECES

Magnet with Single Conventional Pole Piece

Magnet with Distortion Pole Piece

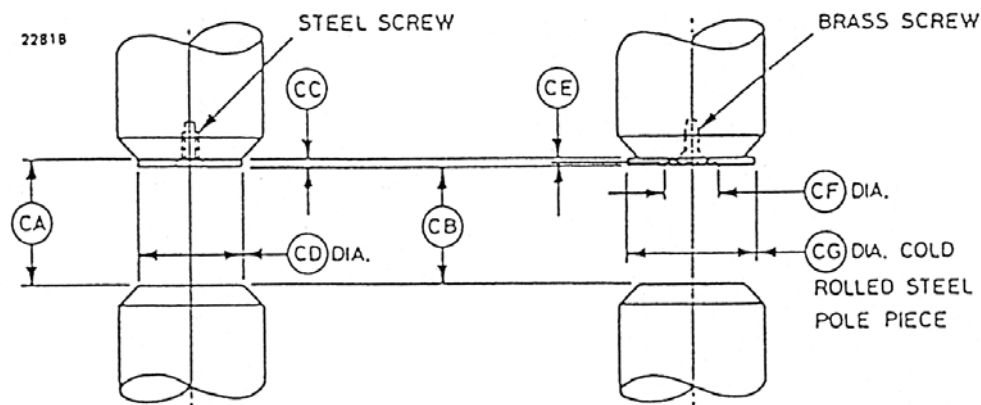

All specifications are subject to change without notice.

New Japan Radio Co., Ltd.

Ref	Inches	Millimeters	Ref	Inches	Millimeters
CA	1.925 ± 0.005	48.90 ± 0.13	CE	0.031 ± 0.015	0.79 ± 0.38
CB	1.800 ± 0.005	45.72 ± 0.13	CF	0.786 ± 0.005	19.96 ± 0.13
CC	0.125 ± 0.015	3.18 ± 0.38	CG	2.000 ± 0.015	50.80 ± 0.38
CD	1.625 ± 0.015	41.28 ± 0.38			

Millimeter dimensions have been derived from inches.

Outline Notes

1. With the magnetron resting on a plane surface the flatness of this annular area will be such that a feeler gauge 0.015 inch (0.38mm) thick and 0.125 inch (3.18mm) wide will not enter more than 0.250 inch (6.35mm) at any point.
2. The periphery of the anode will lie within a 2.160 inches (54.86mm) diameter circle located as specified for the non-tunable side of the anode.
3. The magnetron will be painted with black, heat resisting non-corrosive paint, except for the following paint free areas: top surface of mounting plate, parts above mounting plate, screw threads on guard pipe, all surfaces inside guard pipe, tuning gear, stop and worm shaft assembly.
4. All joints on the mounting plate and guard pipe will be soldered to provide hermetic seals.
5. The magnetron may be supported by the mounting plate or guard pipe.
6. Applies to the location of the centerline of the guard pipe only.
7. Applies to the inner conductor insert only. The centerline of the inner conductor insert will be concentric with the centerline of the guard pipe to within 0.025 inch (0.64mm).
8. Applies to the straight portion of the inner conductor wall.
9. Hexagon locking head banana pin jack, hole 0.169 ± 0.005 inch (4.29 ± 0.13 mm) diameter \times 0.593 inch (15.06mm) long as per Mil-E-1, latest issue.
10. The common cathode connection is marked with letter K.
11. The tuning mechanism will provide the full range of tuning with a maximum of 5 complete revolutions of the large tuning gear.
12. Reference plane A is defined as a plane passing along the face of the mounting plate.
Reference plane B is defined as a plane perpendicular to plane A and passing through the centre of the holes shown.
Reference plane C is defined as a plane mutually perpendicular to plane A and B and passing through the centre of the hole as shown.
13. Tuning spline location; it is possible to move the other side by customer.

All specifications are subject to change without notice.

New Japan Radio Co., Ltd.

COUPLER (All dimensions without limits are nominal)

This coupler matches the output of the magnetron to a standard 1 5/8-inch coaxial line having an outer conductor of 1.527inch (38.79mm) internal diameter and an inner conductor of 0.625inch (15.88mm) diameter.

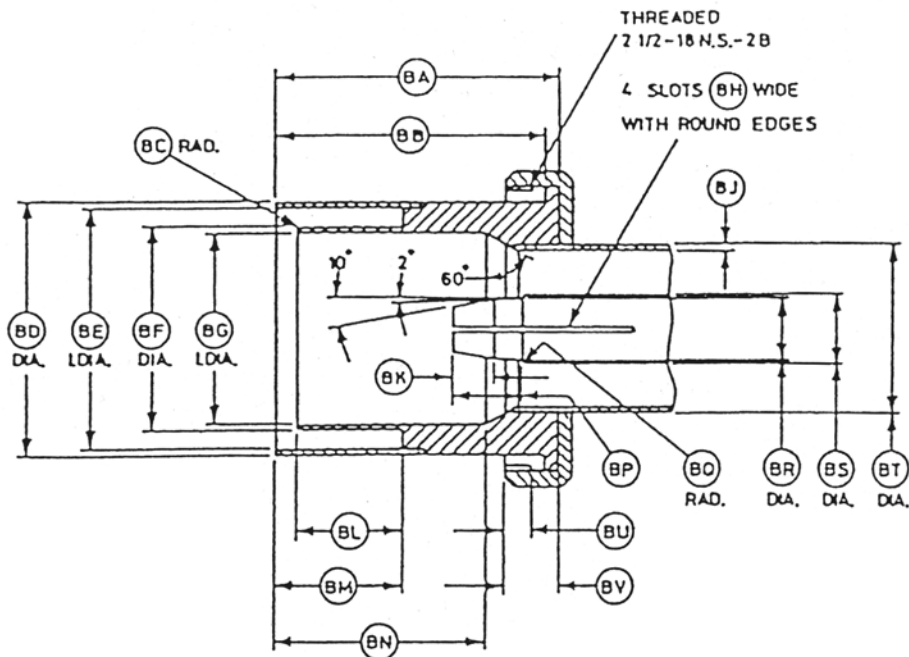

Ref	Inches	Millimeters	Ref	Inches	Millimeters
BA	2.531±0.015	64.29±0.38	BL	0.937±0.003	23.800±0.076
BB	2.402±0.005	61.01±0.13	BM	1.125±0.003	28.575±0.076
BC	0.031±0.015	0.79±0.38	BN	1.875±0.005	47.63±0.13
BD	2.310±0.002	58.674±0.051	BP	0.625±0.015	15.88±0.38
BE	2.185±0.002	55.499±0.051	BQ	0.016±0.015	0.41±0.38
BF	1.875±0.002	47.625±0.051	BR	0.576±0.002	14.630±0.051
BG	1.720±0.002	43.688±0.051	BS	0.625	15.88
BH	0.030	0.76	BT	1.625	41.28
BJ	0.049	1.24	BU	0.250±0.015	6.35±0.38
BK	0.375±0.015	9.53±0.38	BV	0.500±0.015	12.70±0.38

Millimeter dimensions have been derived from inches.

All specifications are subject to change without notice.

New Japan Radio Co., Ltd.